

Maintenance-Free Rechargeable  
Sealed Lead Acid Batteries  
6 volt 12 Ah to 12 volt 260 Ah



## Features

- \* Maintenance Free
- \* Leak Proof / Spill Proof
- \* Gas Recombination
- \* Gelled Electrolyte
- \* Float / Cycle Use
- \* Low Self Discharge Rate
- \* One-Way Safety Valve
- \* Lead Calcium Alloy
- \* Rugged Design
- \* 5 + years design Life
- \* Available Flame Retardant Material (Optional)

## Application

- \* Photovoltaic / Solar
- \* Wheelchairs
- \* EV.Scooters
- \* Telecommunication PABX etc.
- \* Fuse & Security Alarm System
- \* Portable VTR/TV
- \* Power Tools
- \* Computer
- \* Toys - Cars
- \* Fans
- \* Electronic Torch
- \* Emergency Lighting

**Supplied Worldwide by:**

**SOLARTECH (UK) LTD**



## **MICROLYTE Gel - Deep Cycle VRLA Battery**

**MICROLYTE Gel** batteries are designed for deep cycling applications, **SEC** have designed the gelled electrolyte, plate and battery components for maximum performance in deep cycle service. The larger sizes of the **MICROLYTE Gel** 6 volt and 12 volt Monobloc batteries are manufactured using high quality female brass insert terminals to ensure minimum terminal resistance and reliable secure high rate terminal connections.

### **Valve Regulated Sealed VRLA Construction**

The battery is of gelled electrolyte construction, the dilute sulphuric acid electrolyte is immobilized in a specially formulated gelled mixture. All of the acid is absorbed in this manner and it then provides a safe non-spillable deep cycle battery.

### **Gas Recombination System**

The gasses generated during the normal charge/discharge use of a rechargeable battery are internally recombined in the negative plate during normal operation, in fact more than 98% of the gasses generated are recombined in this way.

### **Maintenance**

The gelled VRLA battery design means that there is no need to add water to the electrolyte throughout the 5+ year design life, so in this respect this can be considered a maintenance free battery.

### **Battery Life - in Float Service**

When used in float / standby service and being charged at 13.5 to 13.8 Volts (6.75 to 6.90 Volts) at 20°C. the **MICROLYTE Gel** battery has a design life of about 5 years.

### **Battery Life – in Deep Cycle Service**

When used in cyclic service at 20°C. the **MICROLYTE Gel** battery will have a life expectancy, which will depend on the depth and frequency of the cycles. See curve.

### **One-Way Safety Valve**

If excessive pressure builds up in the battery during over charging the safety valve will automatically open to release the gas at 1 – 3 p.s.i., when the pressure is reduced the valve will close. The one-way valve does not allow the ingress of oxygen, which is harmful to the efficient operation, and life of the battery.

### **Temperature Range for Normal Operation**

The **SEC MICROLYTE Gel** has a wide operating temperature range from –25°C. to +40°C. however the operating design temperature is 20° to 25°C. If batteries are operated at lower temperatures the performance will be reduced if operated at higher temperature the life will be reduced. Operation at over 45°C. is not recommended.

### **Grid Design and Paste Formulation**

The **MICROLYTE Gel** battery has optimized grid design and paste formulation to maximize the operating and storage life of the battery. This optimized design provides the following advantages: - excellent recovery from deep discharge or over discharge and low self discharge to ensure maximum storage time when not in use with excellent cycling capability.

### **For Use In Any Position**

The **SEC MICROLYTE Gel** battery with its gelled immobilized electrolyte can be used upright or on its side. Installation and use in an upside down position is NOT recommended.

## MICROLYTE Gel - Battery Discharge Data to 1.75 vpc at 20 C.

SEC Battery Type	Volts	Capacity Amp Hour 100Hr 1.80	Capacity Amp Hour 48Hr 1.80	Capacity Amp Hour 20Hr 1.75	Capacity Amp Hour 10Hr 1.75	Capacity Amp Hour 8Hr 1.75	Capacity Amp Hour 5Hr 1.75	Capacity Amp Hour 3Hr 1.75	Capacity Amp Hour 2Hr 1.75	Capacity Amp Hour 1Hr 1.75
------------------	-------	------------------------------	-----------------------------	-----------------------------	-----------------------------	----------------------------	----------------------------	----------------------------	----------------------------	----------------------------

6MG-12	6	11.6	10.6	10.0	9.10	8.83	8.46	7.83	6.77	5.56
6MG-130	6	130	122.0	120	108	104	93.0	85.0	79.0	65.0
6MG-200	6	197	185.0	182	164	157	141	129	120	98.0
6MG-220	6	217	204.0	200	180	175	155	142	131	108

12MG-7.5	12	7.62	6.96	6.50	6.00	5.76	5.58	5.16	4.46	3.66
12MG-12	12	11.6	10.6	10.0	9.10	8.74	8.46	7.83	6.77	5.56
12MG-20	12	18.5	16.9	16.0	14.6	14.0	13.5	12.5	10.8	8.89
12MG-30	12	27.7	25.3	24.0	21.8	21.0	20.3	18.8	16.2	13.3
12MG-35	12	34.0	32.0	31.0	27.9	26.8	24.0	22.0	19.2	15.6
12MG-45	12	43.0	41.0	40.0	36.0	35.0	31.0	28.0	26.0	22.0
12MG-60	12	60.0	56.0	55.0	50.0	48.0	43.0	39.0	36.0	30.0
12MG-75	12	76.0	72.0	70.0	63.0	61.0	54.0	50.0	46.0	38.0
12MG-85	12	85.0	80.0	78.0	70.0	67.0	60.0	56.0	51.0	42.0
12MG-100	12	99.0	94.0	90.0	81.0	78.0	70.0	64.0	59.0	49.0
12MG-110	12	108	102	100	90.0	86.0	77.0	71.0	66.0	54.0
12MG-120	12	119	112	110	99.0	95.0	85.0	78.0	72.0	59.0
12MG-130	12	130	122	120	108	104	93.0	85.0	79.0	65.0
12MG-165	12	163	153	150	135	130	116	107	99.0	81.0
12MG-200	12	196	183	180	162	156	139	128	118	97.0
12MG-220	12	220	204	200	180	173	155	142	131	108
12MG-260	12	255	237	232	209	200	180	165	152	125

### Battery Life

Battery Life depends on a number of key factors. These include:

- \* Operating temperature of the battery
- \* Method of charging
- \* Actual use of the product i.e. Float or cycle life
- \* Correct sizing etc.

### Float Service

The life of a battery in float service is affected by the factors listed above, in particular operating temperature and float voltage on charge.

### Cycle Life

The life of a battery in cycle service is dependent on the depth of discharge of each cycle and operating temperature. The greater the depth of discharge of each cycle the lesser the number of cycles available from the battery and higher the operating temperature the shorter the battery life.

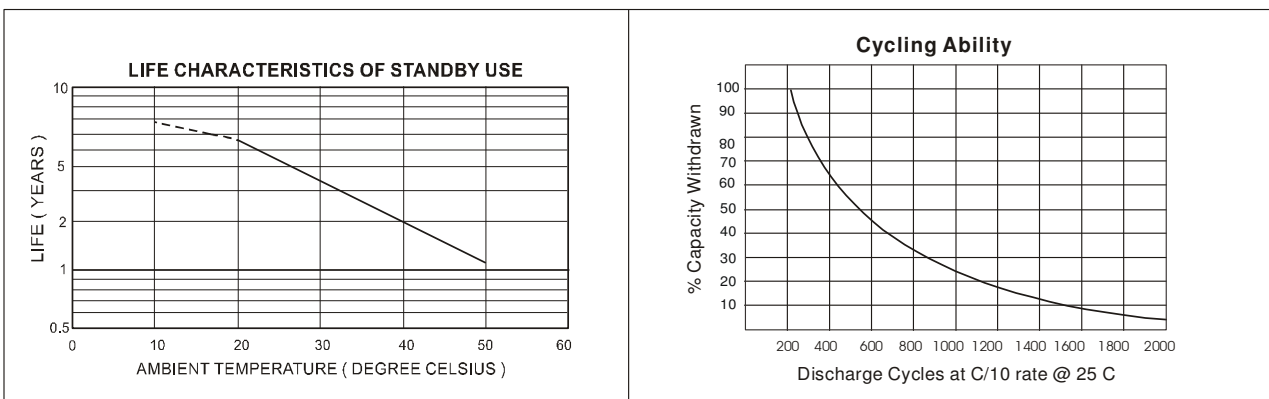

# MICROLYTE Gel - Dimensions & Weights

SEC Battery Type	Volts	Quantity Battery per Carton	Maximum Charging Amps	Maximum Discharge 5 Sec	BATTERY DIMENSIONS			Battery Weight KG	Terminal Type
					Length mm	Width mm	Height mm H1		
6MG-12	6	10	1.69	160	151	50.0	99.5	2.00	ST 2
6MG-130	6	1	18.6	1100	193	168	205	16	FT 3
6MG-200	6	1	28.2	1300	298	171	226	26	FT 4
6MG-220	6	1	31.0	1800	374	171	220	36	FT 4
12MG-7.5	12	8	1.12	95	150	64.5	101	2.50	ST 2
12MG-12	12	4	1.69	160	151	97.5	102	3.95	ST 2
12MG-20	12	2	2.71	220	180	76.0	167	5.96	FT 2
12MG-30	12	1	4.06	260	165	175	125	8.52	FT 2
12MG-35	12	1	4.80	300	194	130	167	12.0	FT 3
12MG-45	12	1	6.20	450	196	164	171	14.0	FT 3
12MG-60	12	1	8.60	540	228	137	214	18.7	FT 3
12MG-75	12	1	10.80	680	257	166	174	25.0	FT 3
12MG-85	12	1	12.00	720	259	166	214	28.0	FT 3
12MG-100	12	1	14.00	800	304	166	214	29.5	FT 3
12MG-110	12	1	15.40	850	304	166	214	30.0	FT 3
12MG-120	12	1	17.00	950	327	171	214	33.0	FT 3
12MG-130	12	1	18.60	1000	406	172	234	39.0	FT 3
12MG-165	12	1	23.20	1200	480	171	240	47.0	FT 4
12MG-200	12	1	27.80	1400	530	209	214	55.0	FT 4
12MG-220	12	1	31.00	1800	530	238	240	65.0	FT 4
12MG-260	12	1	36.00	1900	521	269	205	75.0	FT 5

Actual battery dimensions may vary by +1%

## Case Dimensions

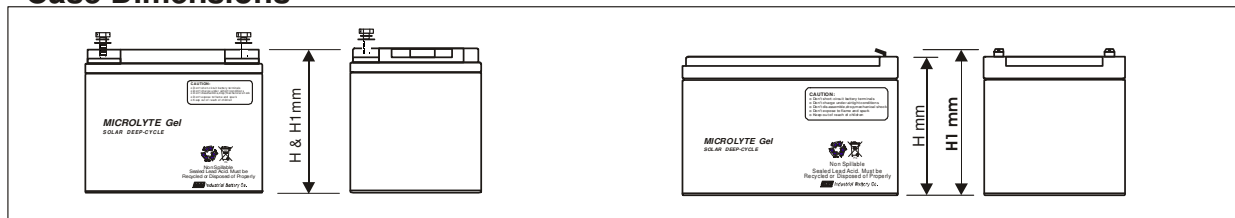

## Terminal Type and Details

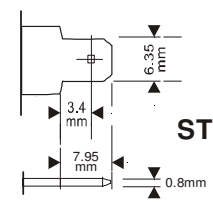

**ST2**

(FASTON TAB No. 250)

**Type FT 2**  
12 mm Dia. Brass Insert Terminal for M5 Bolt

**Type FT 3**  
14 mm Dia. Brass Insert Terminal for M6 Bolt

**Type FT 4**  
16 mm Dia. Brass Insert Terminal for M6 Bolt

**Type FT 5**  
18 mm Dia. Brass Insert Terminal for M8 Bolt

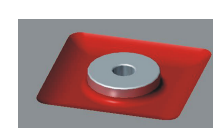

Typical View of Female Terminal

## Terminal Position

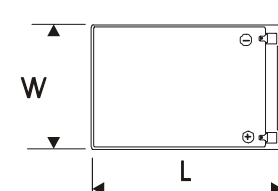

**ST 2**  
Faston Tab

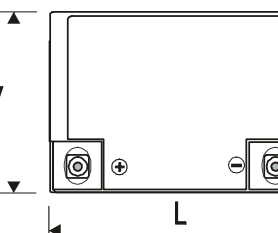

**FT 2 to FT 5**  
Female Terminal

### Battery Storage

SEC **MICROLYTE** Gel Batteries have excellent charge retention characteristics, meaning that the self-discharge rate is low, less than 2% per month at 20 Deg C. To ensure the battery does not over discharge during storage, or when not in use, it is necessary to understand what is meant by fully discharged. A discharged battery can be determined by the open circuit voltage of the battery. Typically a battery is fully discharged when the open circuit voltage reaches 1.92 Vpc (11.5V) in a 12V battery.

### Final Acceptable Discharge

Discharge Current	Final Discharge Voltage
Up to 0.1 A	1.75
0.11 to 0.17 CA	1.70
0.18 to 0.25 CA	1.67
0.26 to 0.6 CA	1.60

In discharging a battery, lead sulphate (sulphation) is formed. If the battery is recharged as soon as discharge is completed then the lead sulphate is converted back into active material and electrolyte. However, on self discharge the lead sulphate that is formed may become non recoverable. That is, it cannot be recharged. The lower the voltage that a battery is allowed to fall to under self discharge, the more likely it is that the sulphate formation will not be reversible and the battery will be damaged beyond recovery.

### Precautions against over Self Discharge

- \* **The batteries should be stored in a cool, dry place 25C or below**
- \* **The batteries should not be stored in direct sunlight.**
- \* **The batteries should not be subjected to an external heat source.**
- \* **An adequate stock control system should be introduced - first in first out basis.**

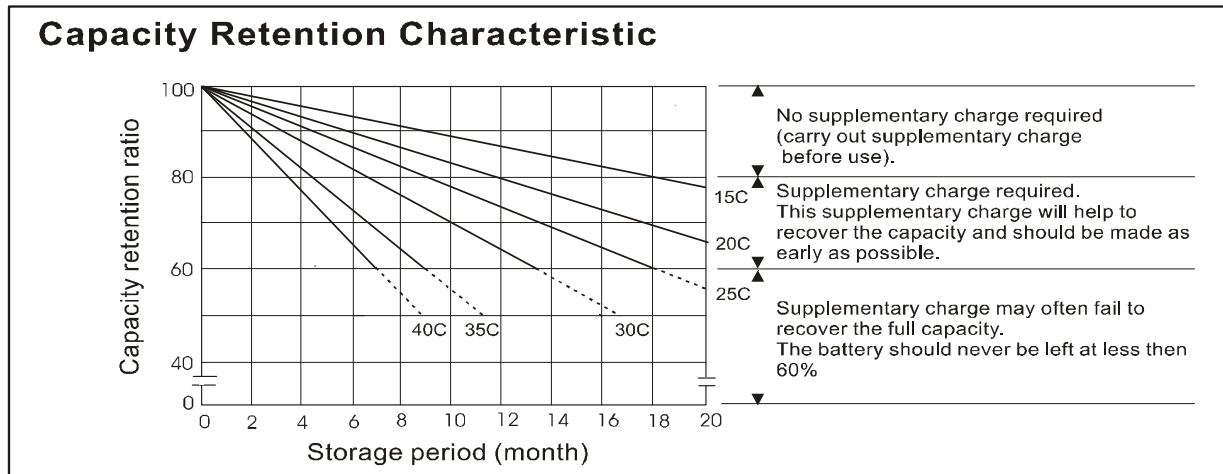

### Supplementary Charge

It may be necessary to give the batteries a refreshing charge during the period the batteries are being stored. Maximum recommended storage times are detailed below, if storage exceeds these times or the open circuit voltage of a battery being stored falls below 12.40 Vpc (6.2 Vpc) then it is recommended the batteries be given a 12 to 24 hour boost charge immediately at 2.33 - 2.43 Vpc.at 20-25C

Storage Temperature	Charging Interval
20 Deg C or less	Every 9 months
25 Deg C - 30 Deg C	Every 6 months
30 Deg C - 40 Deg C	Every 3 months

# 100 Hr Rate Capacity Selection Chart

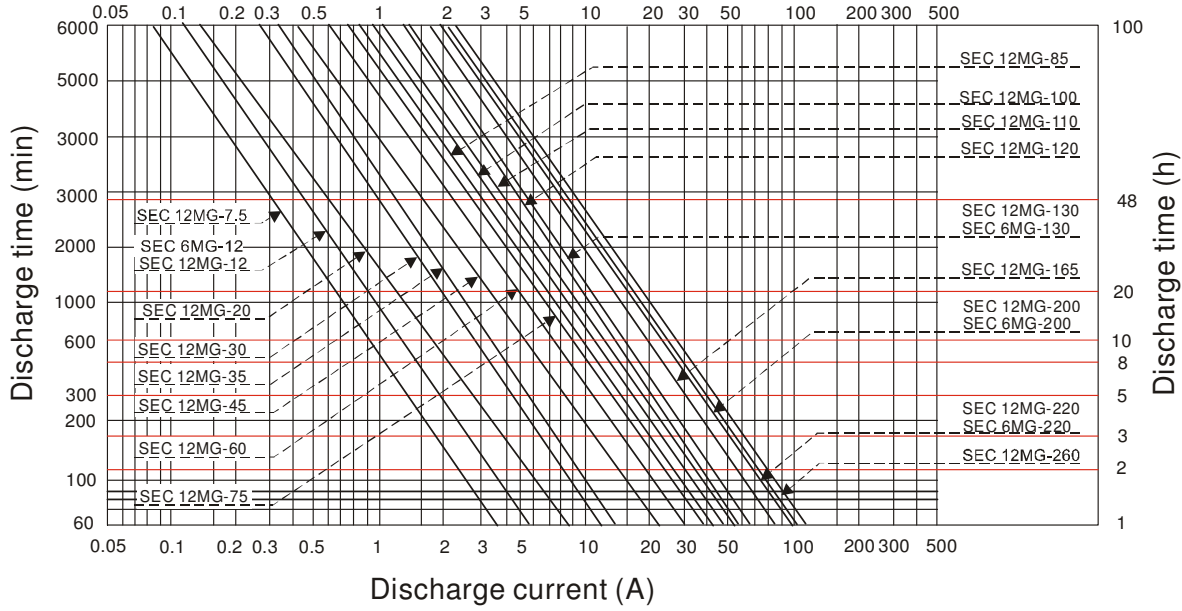

## Temperature and Discharge Capacity

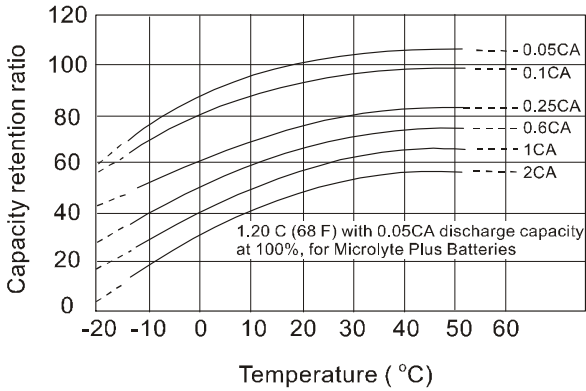

## Discharge Characteristics at various rates (25C)

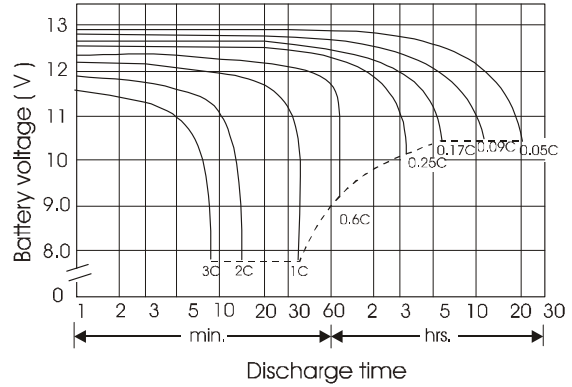

## Multi Terminal Adaptor

For the insert type terminal battery models a Multi Terminal Adaptor is available to convert the insert terminal to a wide range of different terminals. (Figure 1)

J Type  
Semi Auto (SAE)  
Flag Type

